

- N°4 BORCHIE - ALTEZZA H = 7.5  
FORI Ø6.5 - INTERASSE Ø336.9 ±0.15  
- N°4 BOSSES - HEIGHT H = 7.5  
HOLES Ø6.5 - INTERAXLE Ø336.9 ±0.15

- N°4 GANCI PER PERNI Ø6  
INTERASSE Ø340.1 ±0.15  
- N°4 HOOKS Ø6  
INTERAXLE Ø340.1 ±0.15

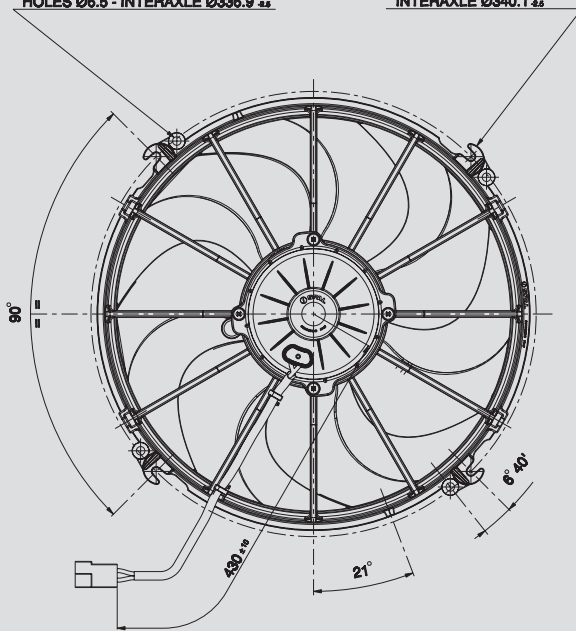

SEDE PER ANELLO IN GOMMA  
RUBBER RING HOUSING

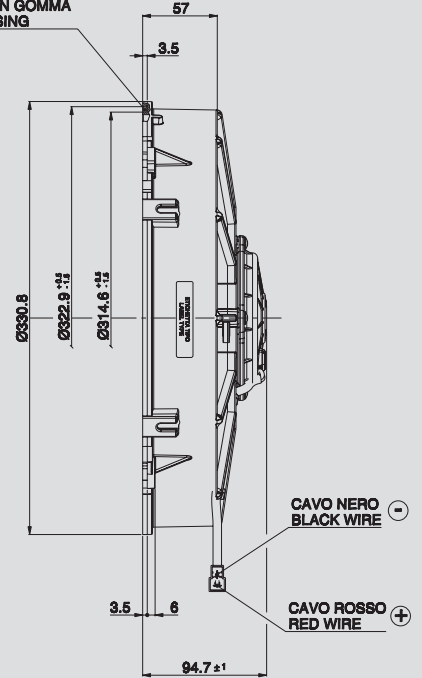

Ø 305 mm  
Ø 12"

Suggested mounting torque: 3(+1/-0) Nm with screw M5  
Weight 2.47 Kg. approx.

Coppia di serraggio consigliata: 3(+1/-0) Nm con vite M5  
Peso 2,47 Kg. circa

PRODUCT FEATURES  
CARATTERISTICHE PRODOTTO

suction / aspirante

blowing / soffiante

Waterproof motor, IP 68 Motore chiuso, IP 68	✓
Low noise / Bassa rumorosità	✓
Long life / Lunga durata	✓
VLL version* / Versione VLL*	✓
Waterproof connector Connettori a tenuta stagna	✓
Accessories: all the fixing kits Accessori: tutti i kit di fissaggio	✓

Static pressure Pressione statica mm H <sub>2</sub> O	suction / aspirante			blowing / soffiante			Static pressure Pressione statica inH <sub>2</sub> O
	Airflow Portata m <sup>3</sup> /h	Current input Corrente assorbita A	Airflow Portata CFM	Airflow Portata m <sup>3</sup> /h	Current input Corrente assorbita A	Airflow Portata CFM	
0	2650	7,1	1564	2850	8,5	1682	0
5	2390	7,5	1410	2630	8,9	1552	0,2
10	2070	8,0	1221	2360	9,3	1392	0,4
15	1700	8,2	1003	2000	9,5	1180	0,6
20	1120	8,4	661	1550	9,8	915	0,8
25	700	8,9	413	1020	10,0	602	1
30	420	9,6	248	620	10,3	366	1,2
35	210	10,5	124	370	11,0	218	1,4
40	0	11,6	0	90	12,0	53	1,6
45				0	12,4	0	1,8

\* for OEM applications only.  
\* per applicazioni OEM

✓ = Standard feature  
Caratteristiche standard  
✓ = Available upon request  
Disponibile su richiesta

Test voltage 26 V. D.C. - Tensione di prova 26 V. c.c.